

Pond Vacuum Series - The Muck Buster

Specifications

Model	PVII	PVII-Plus	PV Pro	Power-Cyclone	
Rated Voltage (V)	AC 110-120V or 220-240V / 50-60Hz				
Vacuum motor power consumption (W)	1150 / 1.5			1200	
Exhaust water pump power consumption (W)	X	X	X	700W For 110-120V	900W For 220-240V
Exhaust water pump flow (GPH/LPH)	X	X	X	3700 / 14000	
Water Drain Out in Second	25-30	30-35	40-45	-	
Container capacity (Gal/L)	5.3 / 20	6.6 / 25	9.5 / 36	13.2 / 50	
Suction hose length (ft/M)	16.4 / 5			26.2 / 8	
Discharge hose length (ft/M)	8.2 / 2.5			32.8 / 10	
Plastic pipe length (ft/M)	5.9 / 1.8 (5pcs)			6.0 / 1.8 (4pcs)	
Cable length (ft/M)	16.4 / 5			32.8 / 10	
Weight (lbs/kg)	26 / 11.8	27.1 / 12.3	32.6 / 14.8	70.5 / 32	

· The above specifications are subject to change without prior notice.

Dimensions

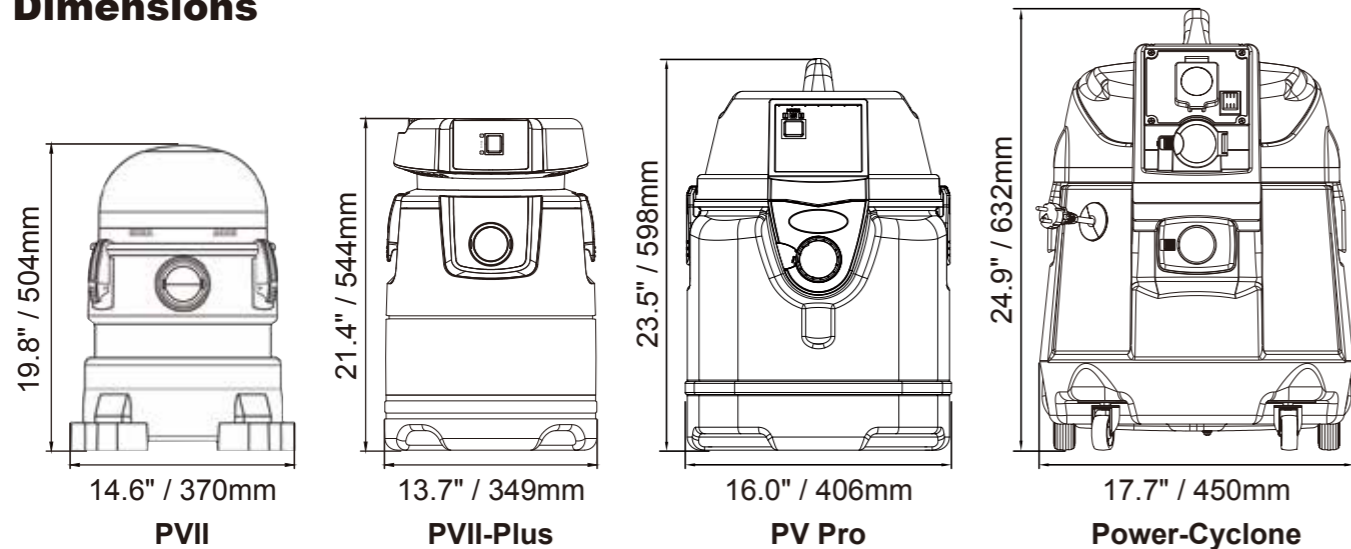

MATALA WATER TECHNOLOGY CO., LTD.

121 Tzu Li 2St., Wu Chi Dist., Taichung City, Taiwan
Tel : +886-4-2630-4015 Fax: +886-4-2630-4067
http: // www.matala.com.tw
e-mail: info@matala.com.tw

DISTRIBUTED BY



150811

Pond Vacuum

The Muck Buster

Pond Maintenance Made Easy



PVII

PVII-Plus

PV Pro

Power-Cyclone

Pond Vacuum Series

Pond Vacuum II&II-Plus&Pro

FEATURE & BENEFITS

- New energy efficient powerful motor.
- 4X more power than competitor
- Suction lift 5 ft. above water
- Auto fill & drain cycle
- 5 extension tubes
- 4 size vacuum heads
- 4pc removable feet
- 4 vacuum heads stands (Easy to keep the vacuum heads when they are not on use)



PVII



PVII-Plus



PV Pro



The "Muck Buster" line of Pond Vacuums offers you 3 sizes of pond vacuum. For small to large ponds, a Matala Pond Vacuum is a great tool to keep your pond in top shape.

All 3 sizes have the same powerful motor. Our new energy efficient German motor design offers the power of a 2 hp with the energy savings of a 1.5 hp. Matala vacuums are known for having great suction power and are very reliable. We use only quality hoses, fittings and connections to ensure you get the job done. The original "Pond Vacuum II" is a great choice for ponds up to 2000 gallons. The "Pond Vac II Plus" and the "Pond Vac PRO"

are suitable for bigger jobs.

Matala "Muck Buster" Vacuums all function on a fill and drain cycle. When the holding tank is full the motor will turn off automatically and the dirty water will drain out to the garden or yard drains downhill by gravity. The "drain out" cycle allows 20 to 40 seconds (depending on vacuum size) to completely drain and then the motor will turn back on automatically to continue vacuuming.

Good pond hygiene will reduce algae growth and improve your fish health. If you have debris building up on the bottom of your pond it may be time for a good pond vacuum.

Power-Cyclone Non Stop Pond Vacuum

FEATURE & BENEFITS

- Powerful non stop vacuum with balanced power discharge pump
- Innovative design with 2 motors
- Internal pre-filter bag
- Easy operation with heavy duty wheels and handle
- Efficient and reliable
- Plastic extension pipe
- 26.2ft/8M intake hose
- 32ft/10M exhaust hose
- Industrial grade
- 1 year limited warranty



Option
Stainless steel extension pipe



Power-Cyclone

This contractor grade continuous vacuum is designed to vacuum large ponds. The innovative "Power-Cyclone" has two motors. One motor for suction and one motor for power discharge for a 1500 gallon per hour Vacuum-Exhaust Capacity. The two motors are balanced in flow rate so the vacuum job is continuous without interruption. The 6 ft extension pipe combines with 26 ft of suction hose allowing for easy handling during even your biggest pond vacuum jobs. Four different size vacuum heads are included.

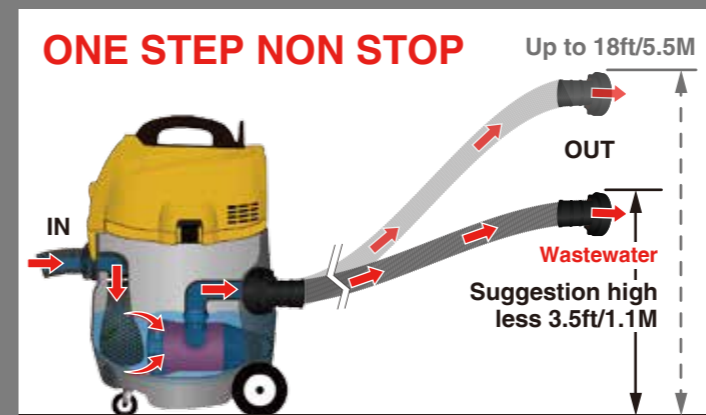

⚠ Don't turn off motor until water completely drains from discharge hose.

Debris is vacuumed into the 13 gallon holding tank whereby large solids are collected into a pre-filter bag first. The dirty water is then pumped out to waste by the action of the internal 1 HP sludge pump. 32 ft of exhaust hose allows the waste water to be pumped to any elevation up to 18 ft high. Total working distance is over 60 ft. An optional secondary exhaust hose can be added onto the end of the discharge hose to gain an additional 32 ft if needed.

Heavy Duty wheels perform over rough terrain & the Tote Handle makes maneuvering easy. This innovative "Power" vacuum is very versatile and can be used in a variety of applications.

- Pond Cleanouts
- Filter Tank Cleanouts
- Basement Floods
- Household Carpet Floods.

Note* Do not return dirty water to the pond. Pump dirty water to your garden or proper drainage system!

ACCESSORIES FOR PVII, PVII-Plus PV PRO



Use finger to adjust air flow

Turn yellow ring on handle to open air vent.



8.2ft/2.5M Discharge hose



16.4ft/5M Suction hose



x5 Extension tubes



3 adjustable floor nozzles (2, 5, 10mm)



Sludge collection bag



Feet / pipe holder

ACCESSORIES FOR POWER-CYCLONE



10ft/3.2M Discharge hose



8ft/26.2M Suction hose



x4 Plastic extension pipe



Crevice tool



Squeegee nozzle



Transparent nozzle



Round brush

